

VENTILATION





Effective heat exchange and simultaneous fresh air ventilation

High Efficiency and low noise levels are achieved by using a highly efficient heat exchange process. A comfortable air conditioned space is achieved by conveniently selecting whether to use heat exchange or normal ventilation setting, according to the requirements of the conditioned space.

- 140 Energy Recovery Ventilator
- 142 Outdoor Air Unit
- 144 DX-Kit for Air Handling Application



PRODUCT LINEUP

Airflow rate (m³/h)	250	350	500	800	1000	1500	2000			
Energy Recovery Ventilator Page 140	 UTZ-BD025B	 UTZ-BD035B	 UTZ-BD050B	 UTZ-BD080B	 UTZ-BD100B					
Outdoor Air Unit Page 142					 ARXH054GTAH	 ARXH072GTAH	 ARXH096GTAH			
Connectable Capacity class (kW)	5.0	6.3	8.0	10.0	12.5	14.0	20.0	25.0	40.0	50.0
DX-Kit for air handling applications Page 144	 EEV unit UTP-VX30A	 Control unit UTY-VDGX		 EEV unit UTP-VX60A	 Control unit UTY-VDGX		 EEV unit UTP-VX90A	 Control unit UTY-VDGX	 EEV unit UTP-VX90A x 2	 Control unit UTY-VDGX



Energy Recovery Ventilator



Energy recovery ventilator unit offers maximum comfort and greater energy savings.

Features

Adopts a highly efficient counter-flow heat exchange element

Heat exchange ventilation and normal ventilation

Heat exchange ventilation
When a room is cooled or heated, the exhausted cooling / heating energy is recovered by heat-exchange ventilation.

Normal ventilation
The operation is used during periods when the room space requires no cooling or heating effect, i.e. when there is minimal temperature difference between the indoor and outdoor environments.

Energy efficiency and ecology

Energy consumption is dramatically reduced by using a counter-flow heat-exchange element. Air conditioning load is reduced by approximately 20%, resulting in significant energy savings. Recovers up to 77% of the heat in the outgoing air.

Features of heat exchange element

With the cross-flow element, air moves in a straight line across the element. With the counter-flow element, air flows through the element for a longer time (longer distance), so the heat-exchange effect remains unchanged.

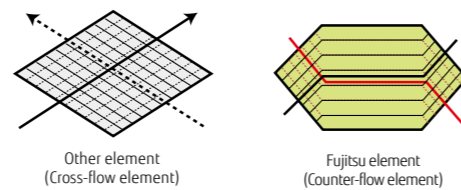

Quiet operation

Significantly reducing low pressure loss and noise allows low-noise operation.

Extended range of an external static pressure

An external static pressure is improved by adopting a powerful fan motor. This allows for application in a wide variety building.

Slim shape and easier installation

Counter-flow heat exchange element used for reduced noise and slimmer, more compact body shape.

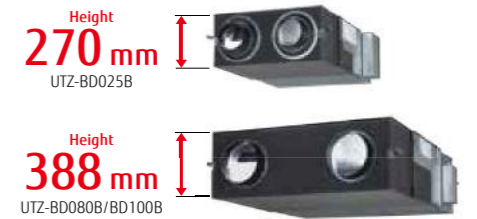

Reverse mountable direct air supply / exhaust system

Adoption of straight air supply / exhaust system: Duct design is simplified because the air supply / exhaust ducts are straight. Since each unit can be mounted in reverse position, only one inspection hole is needed for two units: Two units can share one inspection hole so duct work is easier and more flexible.

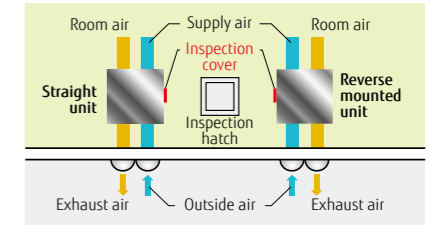

Model : UTZ-BD025B / UTZ-BD035B / UTZ-BD050B / UTZ-BD080B / UTZ-BD100B



Specifications

Rated flow rate		250 m³/h		350 m³/h		500 m³/h		800 m³/h		1000 m³/h	
Model No.		UTZ-BD025B		UTZ-BD035B		UTZ-BD050B		UTZ-BD080B		UTZ-BD100B	
Power source		220 - 240V, 50Hz									
Heat Exchange Ventilation	Input power	(Extra high)/High/Low	W	128 / 123 / 96	190 / 185 / 168	289 / 225 / 185	418 / 378 / 295	464 / 432 / 311			
	Air flow rate	(Extra high)/High/Low	m³/h	250 / 250 / 190	350 / 350 / 240	500 / 500 / 440	800 / 800 / 630	1000 / 1000 / 700			
	External static pressure	(Extra high)/High/Low	Pa	105 / 95 / 45	140 / 60 / 45	120 / 60 / 35	140 / 110 / 55	105 / 80 / 75			
	Temperature Exchange Efficiency	(Extra high)/High/Low	%	75 / 75 / 77	75 / 75 / 78	75 / 75 / 76	75 / 75 / 76	75 / 75 / 79			
	Energy Exchange Efficiency Cooling	(Extra high)/High/Low	%	63 / 63 / 65	66 / 66 / 71	62 / 62 / 64	65 / 65 / 68	65 / 65 / 70			
	Energy Exchange Efficiency Heat pump	(Extra high)/High/Low	%	70 / 70 / 72	69 / 69 / 73	67 / 67 / 69	71 / 71 / 74	71 / 71 / 76			
Normal Ventilation	Sound pressure level	(Extra high)/High/Low	dB*	31.5 / 30.5 / 26.5	33 / 31 / 25.5	37.5 / 35.5 / 32.5	37.5 / 37 / 34.5	38.5 / 37.5 / 34.5			
	Input power	(Extra high)/High/Low	W	128 / 123 / 96	190 / 185 / 168	289 / 225 / 185	418 / 378 / 295	464 / 432 / 311			
	Air flow rate	(Extra high)/High/Low	m³/h	250 / 250 / 190	350 / 350 / 240	500 / 500 / 440	800 / 800 / 630	1000 / 1000 / 700			
	External static pressure	(Extra high)/High/Low	Pa	105 / 95 / 45	140 / 60 / 45	120 / 60 / 35	140 / 110 / 55	105 / 80 / 75			
Sound pressure level	(Extra high)/High/Low	dB*	31.5 / 30.5 / 26.5	33 / 31 / 25.5	38.5 / 38 / 32.5	37.5 / 37 / 34.5	40.5 / 39.5 / 36.5				
Dimensions	W×D×H	mm	882 x 599 x 270	1050 x 804 x 317	1090 x 804 x 317	1322 x 884 x 388	1322 x 1134 x 388				
Weight		kg	29	49	57	71	83				
Outlet duct diameter		mm	150	150	200	250	250				
Operation range		°C	-10 to 40	-10 to 40	-10 to 40	-10 to 40	-10 to 40				
Maximum humidity		%	85	85	85	85	85				

* The noise level must be measured 1.5 m below the centre of the unit.

Dimensions

(Unit : mm)

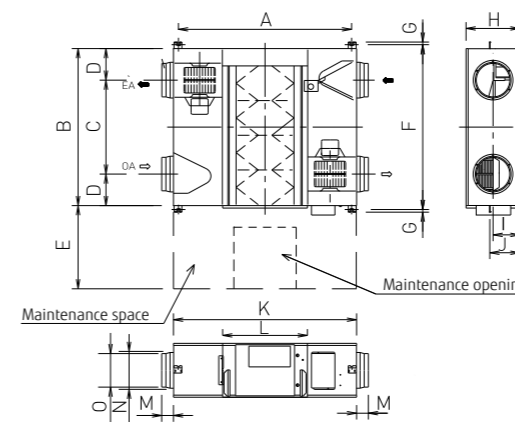

	UTZ-BD025B	UTZ-BD035B	UTZ-BD050B	UTZ-BD080B	UTZ-BD100B
A	810	978	1018	1250	1250
B	599	804	904	884	1134
C	315	580	640	428	678
D	142	112	132	228	228
E	600	600	600	600	600
F	655	860	960	940	1190
G	19	19	19	19	19
H	270	317	317	388	388
I	135	159	159	194	194
J	159	182	182	218	218
K	882	1050	1090	1322	1322
L	414	470	470	612	612
M	95	70	127	85	85
N	219	162	210	258	258
O	144	144	194	242	242

Outdoor Air Unit

The heat pump method efficiently processes the outdoor air for cooling and heating and supplies 100% fresh air into a room.

Features

One VRF system can provide air conditioning and air supply at the same time.

Outdoor Air Unit can be connected in a same VRF*1 system as one of indoor unit series and can create fresh and comfortable air supply together from our high advanced technology.

*1. Connectable VRF series: J-IIS, J-II, V-II, VR-II
In J-II series alone, OAU is prohibit to connect under the ambient temperature of 40°C or higher.

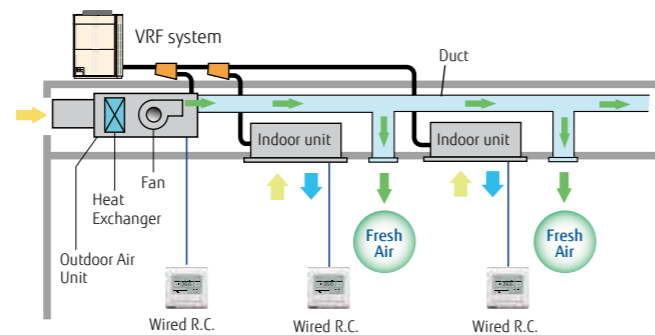
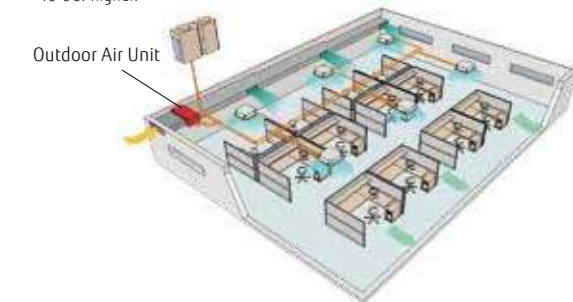

* Make sure the connected capacity is within the range of 50% to 100% of the outdoor unit capacity. In addition, if there are mixed connections with indoor units, make the Outdoor Air Unit connection capacity 30% or less of the outdoor unit capacity.

High energy savings and flexible duct design by using DC motor

- Greatly reduces electricity consumption by adopting permanent magnet compared to when using an AC motor.
- Compared with AC motor, changing the speed makes it possible to respond flexibly to the external static pressure from 50 Pa to 240 Pa. Even if damper equipment is not used, static pressure can be adjusted and duct design is easy.
- Static pressure can be set easily using wired remote controller.

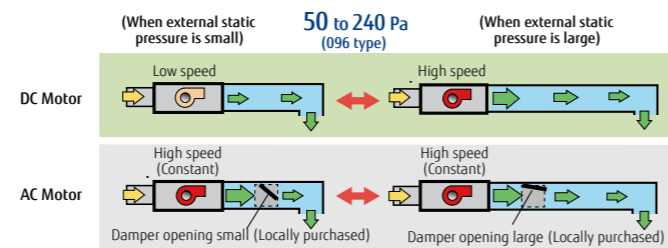

Top class compact design

- Top class lightweight compact design at just 425 mm in height, 55 kg in weight for ARXH072 type. This unit can be installed easily even at narrow space.

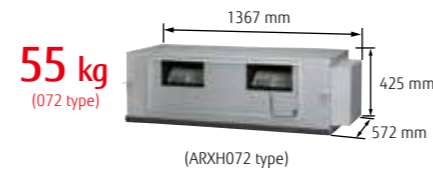

Various Controller

Supplied variety of controllers as options, such as individual controller, central controller, and building management controller.

Individual Controller



Central Controller



* The temperature setting is discharged air temperature setting. The air volume is set to a constant speed.

Model : ARXH054GTAH / ARXH072GTAH / ARXH096GTAH Production by order



ARXH054GTAH



ARXH072GTAH



ARXH096GTAH

Specifications

Model name			ARXH054GTAH	ARXH072GTAH	ARXH096GTAH
Power source	V/Ø/Hz		230/1/50	230/1/50	230/1/50
	Capacity	Cooling	14.0	22.4	28.0
Input Power	Heating	kW	8.9	13.9	17.4
	Cooling/Heating	W	179	292	370
Airflow Rate		m ³ /h	1,080	1,680	2,100
Static Pressure	Standard (range)	Pa	185 (50-185)	200 (50-200)	200 (50-240)
	Sound Pressure Level	dB (A)	42	44	47
Dimensions (H x W x D)		mm	425×1,367×572	425×1,367×572	450×1,583×700
Weight		kg	48	55	71
	Connection Pipe Diameter (Small / Large)	mm	Ø9.52/Ø19.05	Ø12.70/Ø22.22	Ø12.70/Ø22.22
Operation Range	Cooling	°CDB	5 to 43	5 to 43	5 to 43
	Heating	°CDB	-7 to 21	-7 to 21	-7 to 21
Refrigerant			R410A	R410A	R410A

Note : Specifications are based on the following conditions.

Cooling : Outdoor temperature of 33°CDB / 28°CWB.
Heating : Outdoor temperature of 0°CDB / -2.9°CWB.

Pipe length : 7.5 m Voltage : 230 [V].

Dimensions

(Unit : mm)

ARXH054GTAH

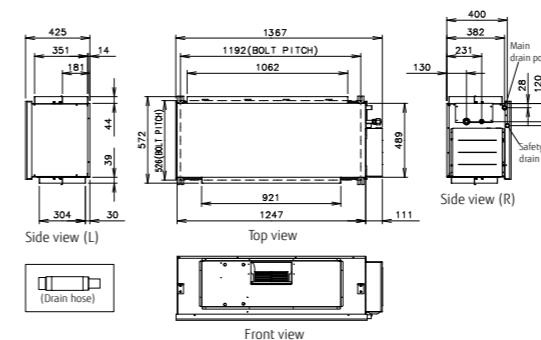

ARXH072GTAH

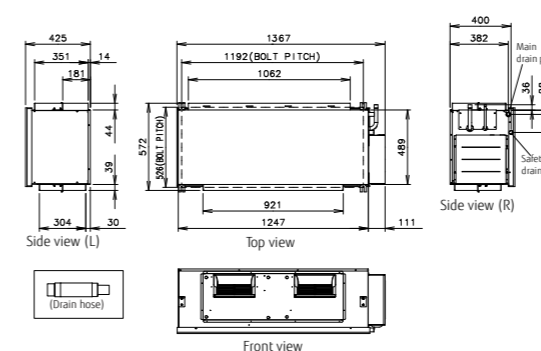

ARXH096GTAH

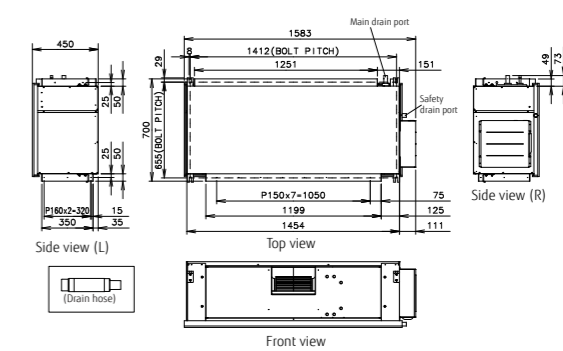

DX-Kit for Air Handling Applications

These kits enable other manufacturers air handling units (AHU) and fan coil units (FCU) to be incorporated into a Fujitsu VRF system or, be connected to a dedicated Fujitsu VRF outdoor unit as a 1:1 system to control outside air ventilation (AHU) or room temperature (FCU).

Features

Multiple temperature sensors optimally control the air handling unit and fan coil unit.

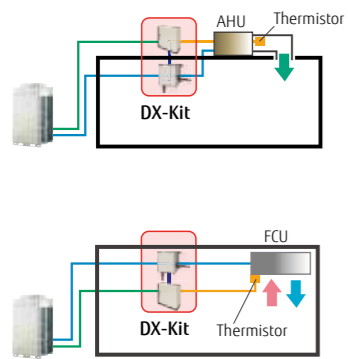

When connecting to an air handling unit, the supply air temperature is controlled by the discharge sensor.

When connecting to a fan coil unit, the room temperature is controlled by the return air temperature sensor.

Arrangement as part of a VRF system

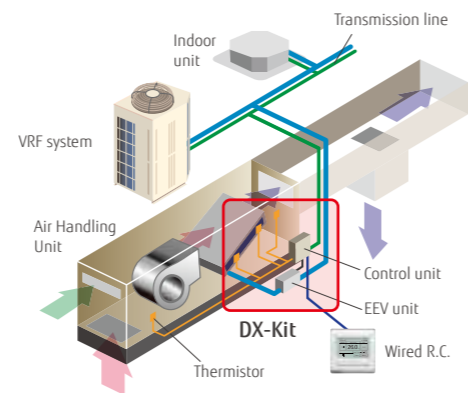

Supports a wide range of capacity classes

- 2 EEV units can be connected in parallel and up to 20 HP (50 kW) large capacity units. (Separation Tube of UTP-LX180A is required.)
- Connectable capacity range: 5 kW to 50 kW

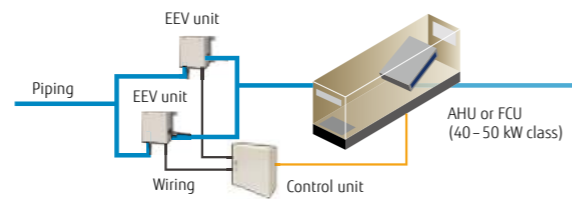

A variety of controls to match the application

Central control using our VRF controllers or central management controllers

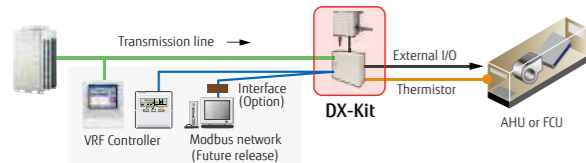

Central control from external controllers

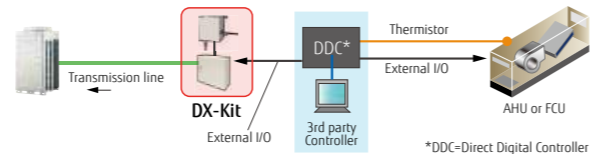

Functions Summary

Inputs

- ON/OFF
- Setting temperature
- Capacity demand
- Heating / Cooling operation mode
- Fault information

Outputs

- ON/OFF indication
- Fan ON/OFF indication
- Thermo ON/OFF indication
- Defrost indication
- Fault indication

MODBUS® Control

Possible to control via a MODBUS enabled BMS by using optional interface.

For 2EEV units connection (option) Separation Tube: UTP-LX180A



Installation Limitation

- Connectable VRF series: J-IIS, J-II, V-II, VR-II
- Connectable DX-Kit system capacity range: 50 to 100% of the outdoor unit capacity
- Connectable DX-Kit system capacity range with indoor units: 30% or less of the outdoor unit capacity
- Max. wiring length from control unit: 10 m
- Max. piping length between EEV unit and indoor unit: 5 m
- Outdoor installation: Control unit (IP54 class) and EEV unit can be installed at an outdoor space.

Connectable capacity

• Single connection



• Mixed connection

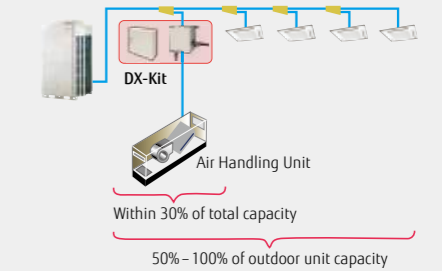

Piping and wiring length

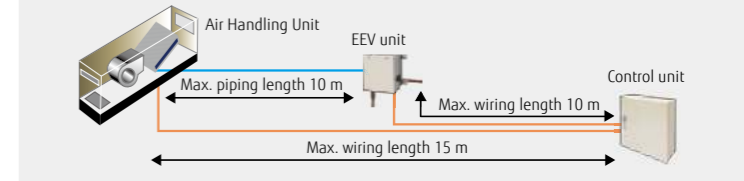

Control unit: UTY-VDGX EEV unit: UTP-VX30A / UTP-VX60A / UTP-VX90A



Specifications

Connectable Capacity class			5.0 kW	6.3 kW	8.0 kW	10.0 kW	12.5 kW	14.0 kW	20.0 kW	25.0 kW	40.0 kW	50.0 kW
Capacity	Cooling	kW	5.6	6.3	8.0	10.0	12.5	14.0	22.4	25.0	40.0	50.4
	Heating	kW	6.3	7.1	9.0	11.2	14.0	16.0	25.0	28.0	45.0	56.5
Control unit			UTY-VDGX									
Power source			230/1/50									
Dimensions (H × W × D)			400 × 400 × 120									
EEV unit			UTP-VX30A		UTP-VX60A		UTP-VX90A		UTP-VX90A×2			
Connection pipe diameter (Liquid)			Ø9.53		Ø12.7		Ø12.7		Ø12.7			
Dimensions (H × W × D)			160 × 220 × 90									

Note: Specifications are based on the following conditions.
Cooling: Indoor temperature of 27°CDB / 19°CWB, and outdoor temperature of 35°CDB / 24°CWB.
Heating: Indoor temperature of 20°CDB / (15°CWB), and outdoor temperature of 7°CDB / 6°CWB.
Pipe length: 7.5 m Voltage: 230 [V].